

WITTEN FASTENERS

150 SERIES - "SPIRAL RIB" THREADED INSERT, BLIND, REGULAR HEAD STYLE HEAVY DUTY, "HIGH PERFORMANCE"

TABLE I

CODE NO.	T THREAD	A DIA ±.010	B SELF-LK ±.06	C DIA ±.010	INSTR HOLE +.010/-.000
632	6-32 UNC	.490	.12	.460	.500
832	8-32 UNC	.490	.12	.460	.500
1032	10-32 UNF	.520	.12	.490	.530
420	1/4-20 UNC	.583	.16	.553	.593
428	1/4-28 UNF	.583	.16	.553	.593
518	5/16-18 UNC	.646	.20	.616	.656
524	5/16-24 UNF	.646	.20	.616	.656
616	3/8-16 UNC	.708	.20	.678	.718
624	3/8-24 UNF	.708	.20	.678	.718
714	7/16-14 UNC	.771	.20	.741	.781
720	7/16-20 UNF	.771	.20	.741	.781
813	1/2-13 UNC	.833	.20	.803	.843
820	1/2-20 UNF	.833	.20	.803	.843

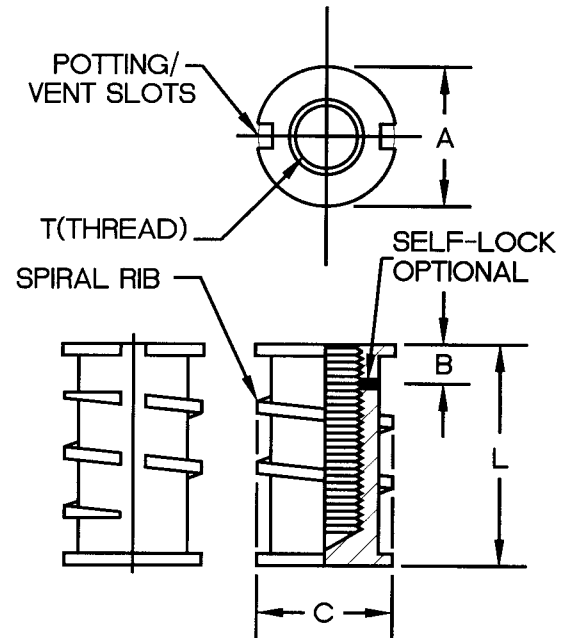
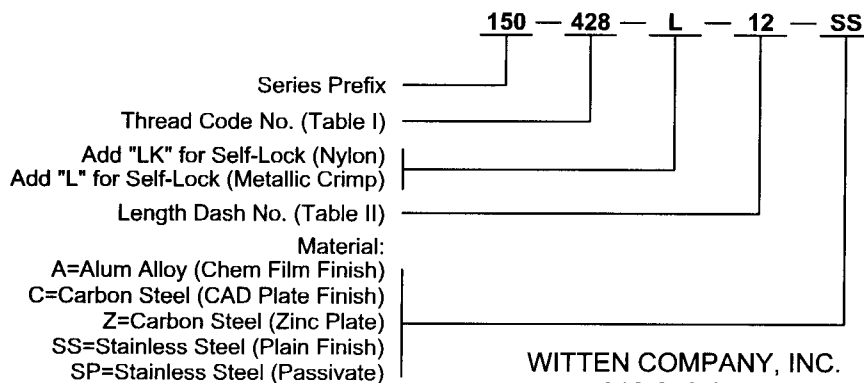

TABLE II

DASH NO.	L ±.03 LENGTH	MINIMUM FULL THREAD DEPTH							
		#6	#8	#10	1/4	5/16	3/8	7/16	1/2
-5	.312	.162	.162	--	--	--	--	--	--
-6	.375	.225	.225	.175	--	--	--	--	--
-7	.437	.276	.287	.237	--	--	--	--	--
-8	.500	.276	.328	.300	.225	--	--	--	--
-10	.625	.276	.328	.375	.350	.350	.350	--	--
-12	.750	.276	.328	.375	.475	.475	.475	.400	.400
-14	.875	.276	.328	.375	.500	.600	.600	.525	.525
-16	1.000	.276	.328	.375	.500	.625	.725	.650	.650
-18	1.125	.276	.328	.375	.500	.625	.750	.775	.775
-20	1.250	.276	.328	.375	.500	.625	.750	.874	.900
-22	1.375	.276	.328	.375	.500	.625	.750	.874	1.000
-24	1.500	.276	.328	.375	.500	.625	.750	.874	1.000

EXAMPLE: PART NUMBERING SYSTEM



Notes:

1. Threads per MIL-S-7742
2. Patent No. 4,941,785 and 5,082,405
3. No. of Spiral Ribs varies with length
4. Installation tabs are available

WITTEN COMPANY, INC.
918-272-9567